

MODEL CXPA120CNS3

SPECIFICATIONS:

- 120,000 BTU/HR at 95°F ambient & 55°F water out
- 60,000 BTU/HR at 95°F ambient & 28°F water out (With LT)
- Electrical: 208/230V, 60hz three phase
- Minimum Circuit Ampacity: 46, Max Fuse Size 60 Amps
- (2) Copeland scroll compressors in tandem
- Stainless Steel Brazed Plate Evaporator [Sized For Glycol]
- R-32 Refrigerant
- 1" FNPT Water/Glycol Connections
- Flow switch safety cut-off
- Low ambient start of 0°F
- Approximate shipping weight 425 LBS
- Dimensions: 48" long, 35-1/2" wide, 43" tall
- ETL & UL Listed Components
- Decibels: 84

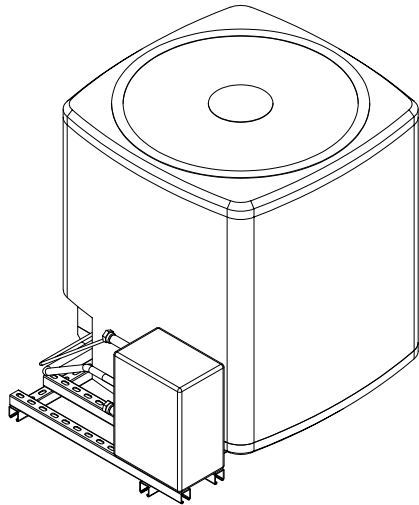

* OPTIONS:

- Controller Extension Cord (+15')
- Low Temp (LWT 25-28F)
- Two-Stage Controller
- Caster Wheels
- Anti-corrosive Condensor Coating
- Hot Gas By-pass

TOP

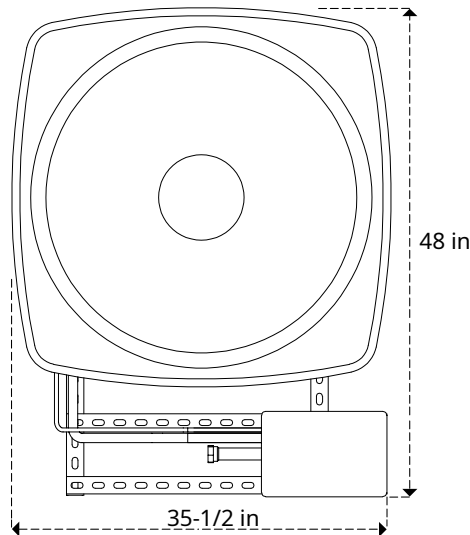

FRONT

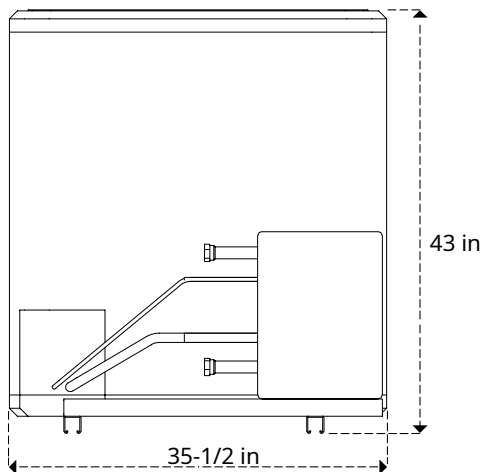

SIDE

